

## Model 2075DWRR Drawer Refrigerator

A 5.5 cubic foot built-in under the counter refrigerated drawer unit.

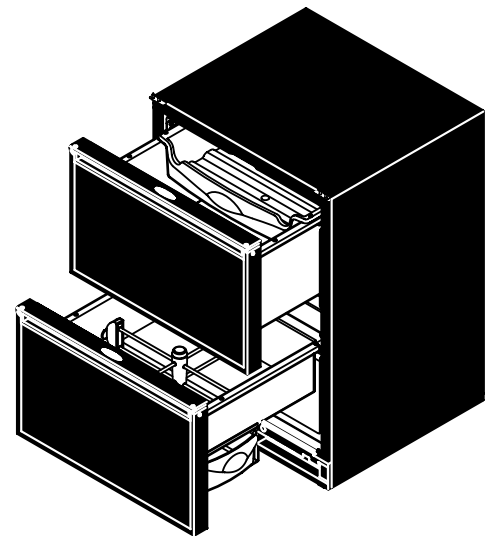
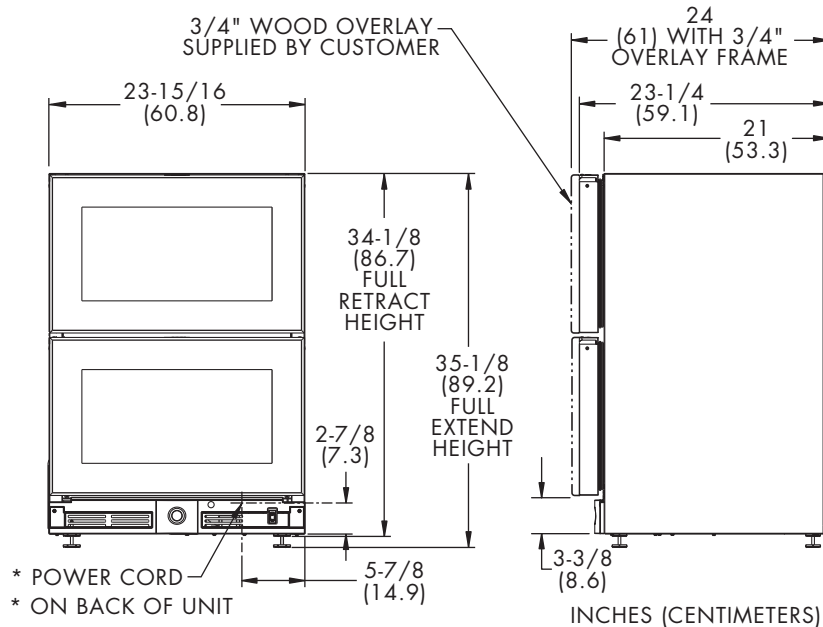

## SUPERIOR FEATURES OF ÉCHELON™

- 1. Easy to set, adjustable, LED temperature controller**  
**BENEFIT:** Digital readout of temperature setting and actual drawer temperatures. Easy ability to see and adjust to desired temperature.
- 2. Black units come standard to accept a full overlay drawer panel**  
**BENEFIT:** Provides a fully integrated appearance with surrounding cabinetry. Overlay panels are easily attached to drawers.
- 3. Full overlay capability allows the customer to choose the size of the gap between drawer panels (either 1/2 or 1/4 inch gap)**  
**BENEFIT:** This provides the customer greater flexibility in matching surrounding cabinetry.
- 4. Stainless steel units have a seamless full wrap stainless steel cabinet and drawers with sculpted, contoured handles**  
**BENEFIT:** The seamless full wrap stainless steel drawers with sculpted handles distinguish this unit from heavier, "commercial" looks.
- 5. Stainless steel drawer interiors**  
**BENEFIT:** Corrosion resistant, sleek professional appearance.

# SUPERIOR FEATURES OF ÉCHELON™

---

## 6. Multiple organizing features

- a. Adjustable Slide & Divide organizer comes standard in the top drawer and can be used in either drawer. Consumer can adjust the organizer from front to back, and side to side.
- b. Clear organizing bin for top drawer can accommodate wine bottles, two-liter bottles, or other items. The bin is designed to slide from the front to rear of the drawer allowing easy access to items in or beneath the bin.
- c. Bottom drawer crisper can be removed from either side of the drawer to easily bring fruit or vegetables to a sink, counter top, or bar.
- d. Glass crisper shelf allows customer to easily see contents of the crisper. Crisper shelf can easily be fully removed to accommodate storage of taller items.

**BENEFIT:** Use of all organizing features allow consumers to customize their refrigeration space.

## 7. Heavy duty, full extension drawer slides

**BENEFIT:** Allows easy accessibility to contents in the back of drawers.

## 8. Lighting in each drawer

**BENEFIT:** Automatically illuminates when either drawer is opened.

## 9. Consumer friendly, self diagnosing controller

**BENEFIT:** In the rare event of a problem, a flashing LED indicator light explains if there is a need to call for service.

## 10. Black units come with flush mounted black drawer panel and will accept a custom 1/4 inch thick panel

**BENEFIT:** Allows customer to achieve a custom, built-in look by matching surrounding cabinetry. Drawers come standard from the factory equipped to be used with full overlay panels. For 1/4 inch custom panel applications, replacement drawer handles are required. Part number 11926-4-BLK.

## 11. Black units have black vinyl clad steel cabinet

**BENEFIT:** A textured, rich look that is more resistant to scratching, peeling and flaking.

## 12. Adjustable leveling legs – durable, factory installed

**BENEFIT:** More precise under the counter fit.

## 13. Automatic defrost

**BENEFIT:** Maintenance free defrosting.

## 14. Anchoring device is included with the unit

**BENEFIT:** This unit must be installed under a counter and must be anchored to prevent tipping if both drawers are opened when full.